

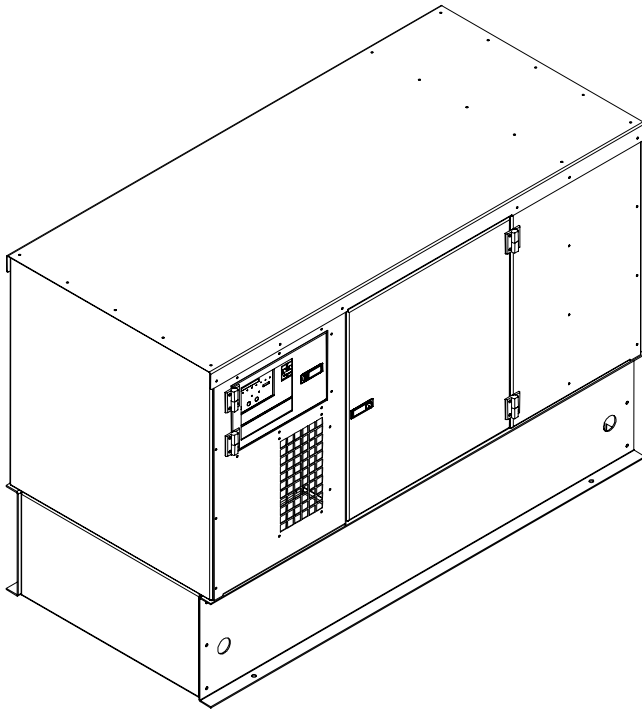

Partech Industries, Inc.

Model: PTA-10S-LO
Diesel Generator Set



FEATURES

- Partech provides one-source responsibility for the generator system and its accessories.
- All units and components are factory tested during prototype and manufacturing stages assuring long product life.
- Generator set accepts one-step 100% of full load per NFPA 110.
- A **one-year limited warranty** covers all systems and components. Extended warranties are available.
- Rugged 4 cycle heavy-duty diesel engine, with direct fuel injection system and swirl intake ports combine for a low fuel consumption and excellent transient response.
- **Generator features:**
 - Unique Volts per Hertz compensated electronic AVR excitation system delivers reliable voltage response for in rush loads.
 - Brushless, rotating-field generator has low reactance, 2/3 pitch, class H insulation, minimizes voltage distortion when powering non-linear loads.
- **More features:**
 - Controllers are available to meet your most demanding applications.
 - In the event of low oil pressure or high coolant temperature the self-protecting system will automatically stop the engine.

GENERATOR SET RATINGS

Model	Volt Code	Voltage	Winding Connection	Phase	Power Factor	Hz	Amps Standby	Standby KW/kVA	Prime kW//kVA
PTA-10S-LO	61	480/277	12 - HI WYE	3	0.8	60	12	8/10	7.7/9.6
PTA-10S-LO	63	440/254	12 - HI WYE	3	0.8	60	13	8/10	7.7/9.6
PTA-10S-LO	64	240/139	12 – HI DELTA	3	0.8	60	24	8/10	7.7/9.6
PTA-10S-LO	65	220/127	12 – LOW WYE	3	0.8	60	26	8/10	7.7/9.6
PTA-10S-LO	66	208/120	12 – LOW WYE	3	0.8	60	28	8/10	7.7/9.6
PTA-10S-LO	67	240/120	12 – 2 DELTA	1	1.0	60	33	8/8	7.7/7.7
PTA-10S-LO	51	415/240	12 – HI WYE	3	0.8	50	12	7/9	6.5/8.1
PTA-10S-LO	53	380/220	12 – HI WYE	3	0.8	50	13	7/9	6.5/8.1
PTA-10S-LO	55	220/127	12 – LOW WYE	3	0.8	50	23	7/9	6.5/8.1
PTA-10S-LO	57	220/110	12 – 2 DELTA	1	1.0	50	32	7/7	6.5/6.5

Stand-By ratings are continuous electrical service during the interruption of normal power. No overload capacity is specified at these ratings. Prime ratings available with variable loads are continuous, 10% overload capacity for one hour in twelve hours periods. Both ratings per BS 5514, DIN 6271, ISO-3046 Many industrial, commercial and residential voltages are available



ALTERNATOR SPECIFICATIONS

Type	Four pole, revolving field
Rotor Insulation	Class H
Temperature Rise	150°C Standby
Material	Epoxy resin
Line-To-Line Harmonic Factor (Max)	5%
Telephone Interference Factor (Tif)	1%
Voltage Regulator	Solid State
Cooling	Self-ventilated and drip proof
Bearing	1 each, pre-lubed
Coupling	Direct, Flexible Disc
Load Capacity (Standby)	100%
Overload Capacity (Prime)	110%
Voltage Regulation	
No Load To Full Load	±1 %
One Step Load Acceptance Per NFPA 110	100%

- ❑ Four pole, revolving field, direct coupled to engine flywheel, provides excellent alignment.
- ❑ Insulation is of class H, ready to be used on harsh environments where sea spray, sand and chemical corrosion are existing factors.
- ❑ Voltage regulator provides Volts/Hertz compensation to improve the motor starting capabilities, therefore support the engine handling transient loads.
- ❑ Dynamically balanced rotor, with damper winding, help dissipate transient voltage interference during load variations.
- ❑ The windings have a 2/3 pitch in order to reduce the harmonic content of voltage.
- ❑ Robust mechanical structure permits easy access to connections.

ENGINE SPECIFICATIONS

Manufacturer	Lombardini
Model	LDW 1003
Bore	2.95in. (75mm)
Stroke	3.06in. (77.6mm)
Number Of Cylinders	3
Piston Displacement	63 in. ³ (1.03L)
Compression Ratio	22.8:1
Combustion System	Indirect Injection
Engine Type	In-Line – 4 Cycle
Aspiration	Nat. Aspirated
Engine Crankcase Vent System	Closed
Cylinder	Borable
Crankshaft Material	Forged Steel
Governor, Make	Mechanical
Frequency Regulation, No Load To Full Load	Lombardini 5 %
Air Cleaner	Dry Element

- ❑ Robust, compact, heavy duty Lombardini diesel engine, for reliable endurance.
- ❑ Many various accessories available along with 4 power take-off points.
- ❑ Indirect fuel injection system with medium turbulence pre-combustion chamber reduces emissions of nitrogen oxides and particulate matter.
- ❑ Use of high precision helicoidal gears, flexible mounting of internal components, and cooling fan design reduce both mechanical and aerodynamic noise levels.
- ❑ Reduced alternating masses along with a pair of dynamic balancers aid in balancing second order alternating forces thereby reducing vibration.

STANDARD EQUIPMENT

ENGINE

- Air Cleaner
- Fuel Pump
- Fuel Filter
- Oil Pump
- Full Flow Oil Filter
- Jacket Water Pump
- Thermostat And Housing
- Exhaust Manifold Dry
- Oil Cooler
- Blower Fan & Fan Drive

- Radiator - Unit Mounted
- Electric Starting Motor 12v
- Housing & Flywheel
- Charging Alternator - 12v
- Battery Kit & Battery Rack

GENERATOR

- Synchronous, Brush-less
- Four Pole
- Single Bearing
- Direct Coupled With Flex
- Class H Insulation
- Drip-Proof Construction

CONTROL PANEL

- Digital Control Panel
- Auto Start Module
- Electric Hour Meter
- Stop-Manual-Auto Pushbuttons
- Standard Engine Control Monitoring
- Automatic Shutdowns
- * High Water Temperature
- * Low Oil Pressure
- *Protective 12vdc Circuit Breakerr --
- Display Lights For:

- * Water Temperature
- * Oil Pressure
- * Overcrank
- * Undercrank
- * Overspeed
- * Battery Charging

GENERAL

- Integrated Fuel Tank
- Industrial Muffler
- Rain Cap
- Lifting Points



INSTALLATION AND APPLICATION DATA

	Item	Units	Type of Operation and Application			
			60 Hz		50 Hz	
			Prime	Standby	Prime	Standby
Engine	Rated Speed	rpm	1800		1500	
	Gross Engine Output	bhp (kWm)	12.2 (9.1)	13.4 (10)	10.3 (7.7)	11.4 (8.5)
	BMEP	psi (kPa)	92 (634)	102 (703)	95 (655)	106 (731)
Cooling System	Ambient Air Temperature	°F (°C)	122 (50)			
	Engine Heat Reject	BTU/min (kW)	518 (9.1)	569 (10)	438 (7.7)	483 (8.5)
	Coolant Flow	gal/min (L/min)	7.4 (28)		6.1 (23)	
	Coolant Capacity	qt (L)	5.2 (4.9)			
	Thermostat Start to Open	°F (°C)	178 (81)			
	Thermostat Fully Open	°F (°C)	201 (94)			
	Blower Fan Diameter	in. (mm)	13.8 (350)			
Fuel System	Total Fuel Flow	gal/hr (L/hr)	25.1 (95)		26.4 (100)	
	Max. Transfer Pump Suction	ft (m)	7 (2.1)			
	Fuel Type		Diesel No.2			
	Fuel Consumption @ 25% Power	gal/hr (L/hr)	0.25 (0.95)	0.28 (1.06)	0.22 (0.83)	0.24 (0.91)
	Fuel Consumption @ 50% Power	gal/hr (L/hr)	0.43 (1.63)	0.48 (1.82)	0.38 (1.44)	0.42 (1.59)
	Fuel Consumption @ 75% Power	gal/hr (L/hr)	0.57 (2.16)	0.63 (2.38)	0.49 (1.85)	0.55 (2.08)
	Fuel Consumption @ 100% Power	gal/hr (L/hr)	0.72 (2.73)	0.79 (2.99)	0.63 (2.38)	0.69 (2.61)
Air Requirement	Radiator Fan Air Flow	ft ³ /min (m ³ /min)	1695 (48)		1440 (41)	
	Air Flow Restriction (After Radiator)	In.H ₂ O (kPa)	0.5 (0.12)			
	Engine Combustion Air Inlet Flow	ft ³ /min (m ³ /min)	31.8 (0.9)	31.8 (0.9)	26.5 (0.75)	26.5 (0.75)
	Air Intake Restriction	In.H ₂ O (kPa)	12.8 (3.2)			
	Exhaust Temperature	°F (°C)	842 (450)		797 (425)	
	Maximun Allowable Back Pressure	In.H ₂ O (kPa)	43.8 (10.9)			
	Connection Outlet Size Diameter	In. (mm)	1.5 (38)			
Lubrication System	Total Engine Oil Cap. w/ Filter(s)	qt (L)	2.5 (2.4)			
	Oil Pan Capacity	qt (L)	2.4 (2.3)			
	Oil Filter Type		Cartridge			
Engine Electricals	Battery Charging Alternator	Volts, Ground	14V, negative			
	Battery Charging Alternator	Rated amps	45			
	Starter Motor	Volts, Ground	12V, negative			
	Recommended Battery Cold Crank	CCA amps	450			
Ambient Deration	Altitude Deration 3% per 1000ft (300m) above	Ft (m)	Sea Level			
	Temperature Deration 2% per 10°F (5.5°C) above	°F (°C)	77 (25)			



OPTIONAL EQUIPMENT

Cooling System

- Remote Radiator
- Jacket Water Heater
- Crankcase Oil Heater

Fuel System

- Fuel/Water Separator
- Day Tank
- Above Ground Fuel Tank
- Auxiliary Fuel Pump
- Sub-Base Fuel Tank
 - Double Wall
 - UL Listed

Exhaust System

- Industrial Grade Muffler
- Residential Grade Muffler
- Critical Grade Muffler
- Super Critical Grade Muffler

Start System

- Battery Nicad

- Battery Warmer Plate
- Battery Charger
 - Automatic Float Equalizing
 - Trickle

Switchgear

- Main Line Circuit Breaker
 - Shunt trip
 - Auxiliary switch
- Automatic Transfer Switch
- Paralleling
- Protective Relays

Generator

- Permanent Magnet Excitation
- Space Heaters
- Temperature Rise Detectors

Control Panel

- Emergency stop button
- Microprocessor Control Panel
- NFPA 110 Ready

- Remote Annunciation Panel
- Audible Alarm

General

- Spring vibration isolators
- Automatic Transfer Switch
- Metal Enclosure
 - Weather Resistant
 - Sound Attenuated
 - Aluminum
- Interior lights AC or DC
- Trailer
- Export Packaging
- Special Testing
- Warranties
 - ____ Year

For Other Options Consult

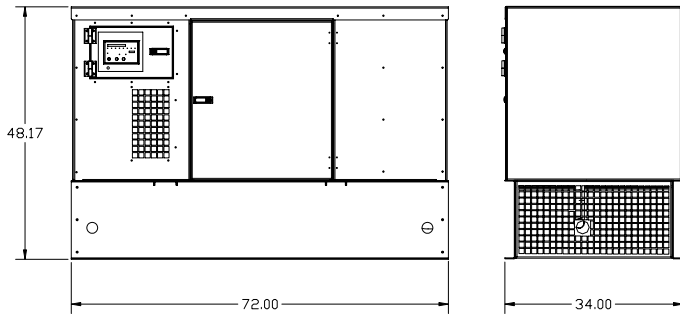

DIMENSIONS AND WEIGHT

	Units	Sound Att. Unit
Length	In. (mm)	72 (1830)
Width	In. (mm)	34 (864)
Height	In. (mm)	48 (1219)
Weight	Lbs (kg)	870 (395)

General configuration for reference only, do not use these dimensions for installation purposes. Contact your local dealer for certified drawings.



All Specifications and Materials are subject to change without prior notice.

Partech Industries, Inc.

5773 NW 151st Street
Miami Lakes, FL 33014 USA

Tel 305-751-0160
Fax 305-757-9809
E-MAIL: sales@partech.us
www.partech.us

